



Restricted - Medical
Employment Medical Advisory Service
Control of Asbestos at Work Regulations 2002

Medical surveillance form

Factory/company name
Factory/company code
HSE use
PIN number

Section A

1. NI number 2. Date of birth 3. Date of examination
(omit final letter)
4. Surname 5. Sex (M/F)

Section B - ONLY TO BE COMPLETED IF THIS IS WORKER'S FIRST ASBESTOS MEDICAL EXAMINATION

1. Full forenames 2. Maiden name/surname at birth (if different)
3. Place of birth 4. NHS number (if known)
5. Address 6. GP's name
7. Date of first exposure to asbestos in current employment 8. IF DIFFERENT: Date of first ever occupational exposure to asbestos
9. Total time NOT in asbestos work between the dates years

Section C

Is the worker's job manufacturing asbestos products (code M), asbestos stripping/removal (code S), or something else (code O)?

Enter code in box Complete the corresponding panel below, then section D

Panel M: Manufacturing

Job Code (see code list M)

In an average week how long do you work in
in a respirator zone hrs
in an asbestos area (but not a respirator zone) hrs

Panel S: Stripping/Removal

Job Code (see code list S)

Do you most often strip wet (W) or Dry (D)

What kind of respirator do you use?
(Full face unpowered - F; Positive pressure mask or blouse - P; other codes in panel O)

In an average week, how long do you spend in a stripping enclosure whilst stripping is going on hrs

Panel O: Other

Job Code (see code list O)

Do you wear a face mask or other protection against breathing asbestos?
(Code: No - N; Minimal e.g. hankerchief, paper mask - M; Half face mask - H; Airstream helmet - A; Other codes in panel S)

Do you ever work with loose asbestos insulation or broken up asbestos insulation board? How often?
(Code: No/Never - N; Daily - D; Weekly - W; Monthly - M; Yearly or less - Y. See note 8)

How often do you come into contact with other kinds of asbestos material? *(Use code as above)*

Which kinds? *(tick box(es))*

1. Intact insulation board	<input type="checkbox"/>
2. Brake and clutch plates	<input type="checkbox"/>
3. Asbestos cement	<input type="checkbox"/>
4. Other	<input type="checkbox"/>

Section D

1. Are you a current smoker (S), ex-smoker (X) or non-smoker (N)
2. At what age did you first smoke regularly?
3. Do/did you smoke mainly cigarettes? Y/N
4. IF MAINLY A CIGARETTE SMOKER: How many cigarettes do/did you smoke per day?
5. IF EX-SMOKER, at what age did you last smoke

Paper mask *CODE M*

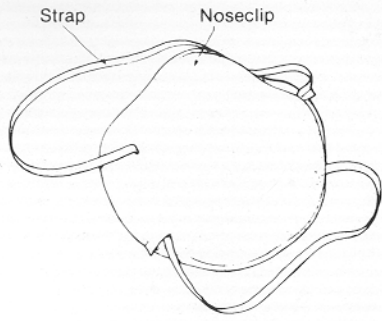

Half face mask *CODE H*

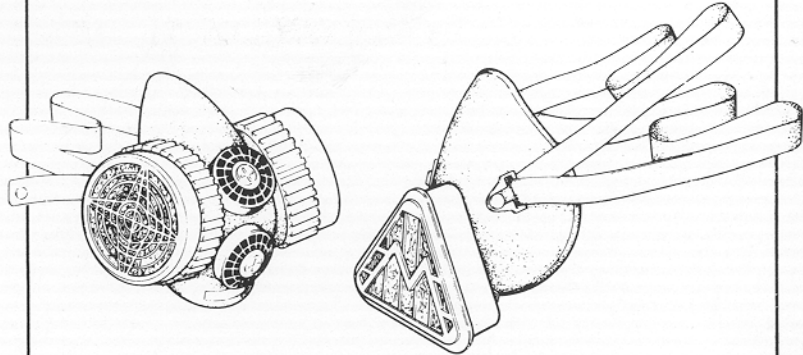

'Airstream' helmet *CODE A*

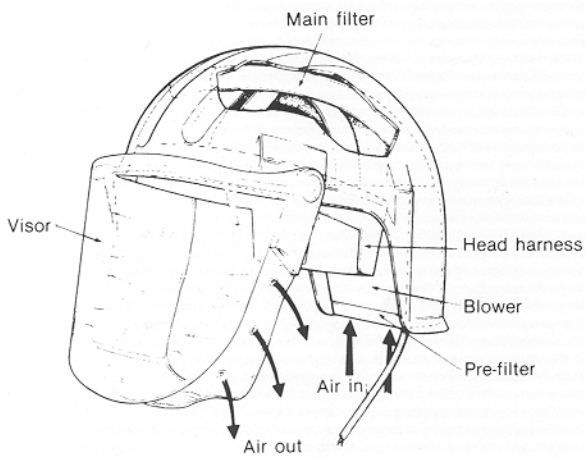

Full face mask (unpowered) *CODE F*

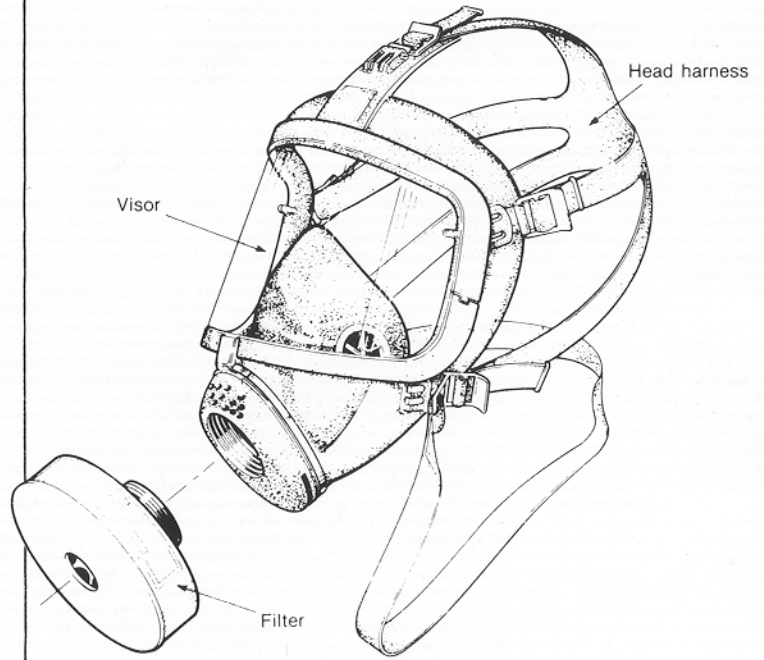

Positive pressure systems *CODE P*

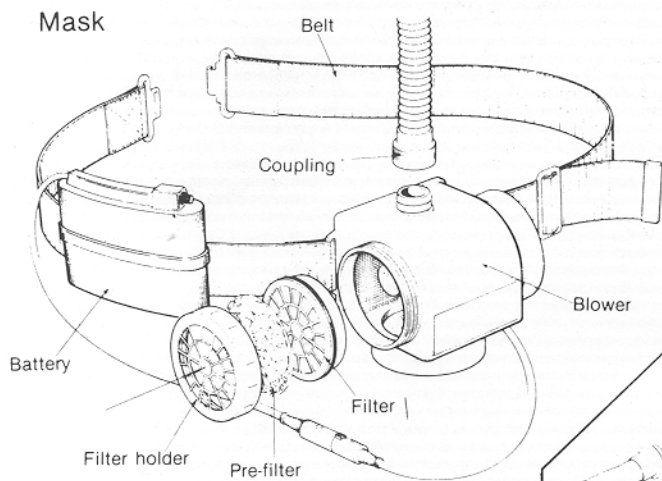

Blouse

